

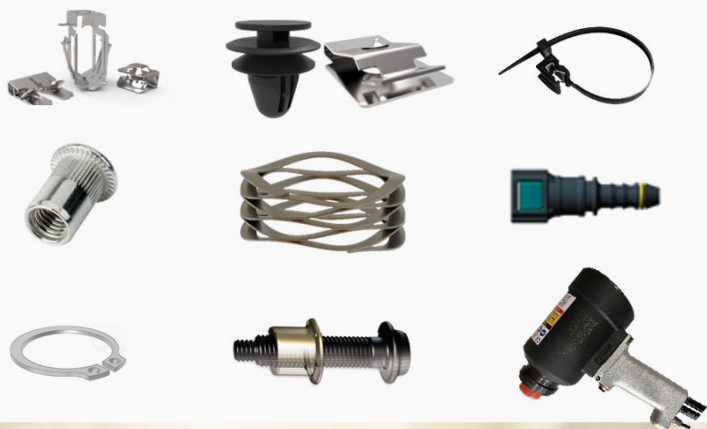

**DB** FASTENERS  
*Helping make the right connections*

# 邓肯勃中国



The People You Call When You Have Fastening Challenges

当您遇到紧固件问题时，就会想到我们









# Overview

## 公司概况

A company founded based on North American customer service values.

一个来自北美的紧固件企业，聚焦服务

A company dedicated to knowledge and understanding of fasteners and related products.

一个知识型企业，更加了解紧固件及相关知识的公司

A company dedicated to following the rules and regulations.

一个合规企业，始终遵守规则和法规

## Mission

### 使命

DB Fastener's mission is to add excellent customer service to our vendors quality products

凭借服务助力合作伙伴成就卓越

## Vision

### 愿景

The People You Call When You Have Fastening Challenges

当您遇到紧固件问题的时候，就会想到我们

## Core Values

### 核心价值

Integrity, Professionalism, Helpfulness

正直，专业，增益

# What can we provide? 我们能提供什么？

Genuine brand name parts for peace of mind in safety critical applications.

真正的品牌件，在安全关键的应用中让您无忧

Tailored fastening solutions for special applications.

定制化的紧固方案

On-site service to keep your production on schedule.

现场服务，确保生产按时进行

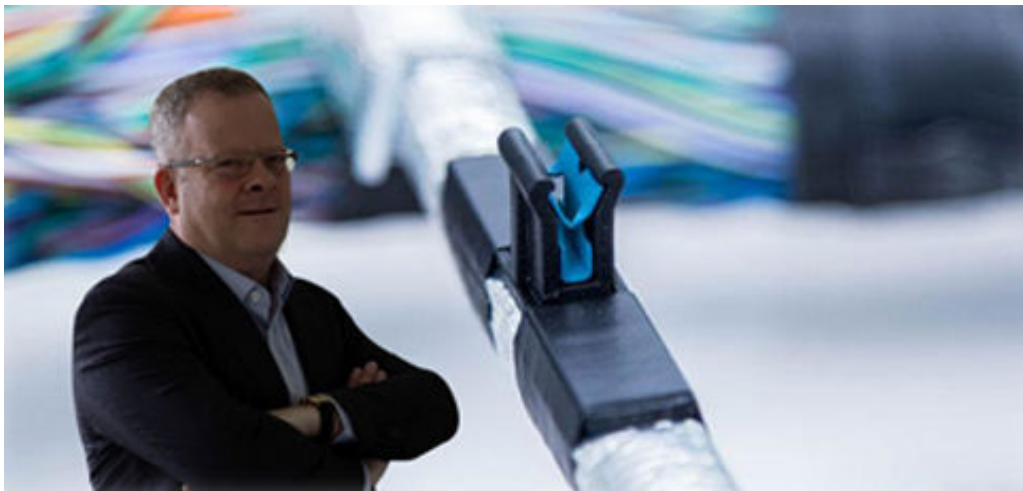

Cable & Tube Fasteners

线束及管路紧固件

Panel & Trim Fasteners

面板与内外饰紧固件

Threaded Fasteners & Retainers

螺纹螺母和弹片螺母



Lock Bolts

环槽铆钉

Structural Blind Rivet

结构盲拉铆钉

Tooling

工具



Blind nuts

盲拉铆螺母

Blind studs

盲拉铆螺柱

Tooling

工具

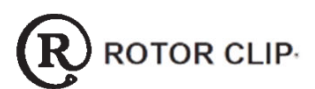

Retaining Rings

止动环

Wave Springs

波形弹簧

Hose Clamps

卡箍



Washer

防松垫圈

Superbolt

超级螺栓

Expander

膨胀销系统

Boltight

液压拉伸系统



DTI

压力指示垫片



ON Flat Surfaces

固定于平面

ON/TO Cables or

Tubes

固定线/管

IN Panel Holes

固定于孔



Caps

盖

Plugs

塞





ARaymond   
MORE THAN FASTENING



# Industry and Applications

## 行业及应用

### Automotive

### 汽车

ARaymond is the global partner of choice for automotive OEMs' and Tier-1 suppliers' fastening and assembly needs.

阿雷蒙致力于为全球汽车制造商及T-1 提供紧固件解决方案。

The line of cable straps / trim clips are compatible with all common mounting strategies (hole, stud, or edge).

其扎带及内外饰卡扣产品适配领域十分广泛。

ARaymond offers innovative solutions for fastening on materials difficult to assemble!

同时针对有些基材上难以装配的固定零件，阿雷蒙会为此提供粘接解决方案！







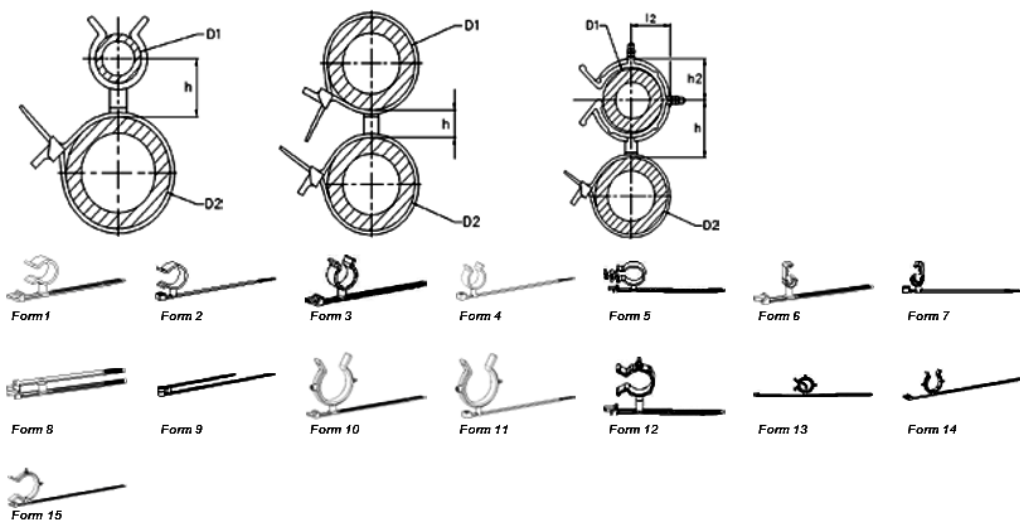

| REF.   | ØD1        | ØD2    | h2 | l2 | h     | Form |
|--------|------------|--------|----|----|-------|------|
| 081047 | 4,3...5,2  | 8...20 | -  | -  | 14.0  | 1    |
| 060828 | 6...6,5    | 8...20 | -  | -  | 14.0  | 1    |
| 081987 | 6...6,5    | 8...20 | -  | -  | 15.5  | 1    |
| 081506 | 7,8...8,5  | 8...20 | -  | -  | 15.2  | 1    |
| 080472 | 8...9      | 8...20 | -  | -  | 15.0  | 1    |
| 080456 | 9,5...10,5 | 8...20 | -  | -  | 17.25 | 1    |
| 081007 | 10...12    | 8...20 | -  | -  | 18.0  | 1    |
| 060698 | 11...13    | 8...20 | -  | -  | 20.0  | 1    |
| 081231 | 11...13    | 8...20 | -  | -  | 18.0  | 1    |
| 081691 | 15...16    | 8...20 | -  | -  | 18.0  | 1    |
| 081530 | 16...18    | 8...20 | -  | -  | 20.5  | 1    |
| 081849 | 18...20    | 8...20 | -  | -  | 19.5  | 1    |
| 081531 | 22...24    | 8...20 | -  | -  | 23.5  | 1    |
| 082550 | 28...30    | 8...20 | -  | -  | 27.0  | 1    |
| 201022 | 28...30    | 8...33 | -  | -  | 27.0  | 1    |
| 201024 | 34...36    | 8...20 | -  | -  | 30.0  | 1    |
| 081043 | 4,3...5,2  | 8...33 | -  | -  | 14.0  | 1    |

Remarks: ARaymond's Part number is generally composed of 9 digits. The main number is composed of the first 6 digits, and the last 3 digits indicate the surface treatment and color requirement. For further information, please scan the QR code or conduct a direct search of the first 6 digits.

备注：阿雷蒙的物料号是由9位数字组成，前6位数字为主料号，最后3位数字表示物料的表面处理等信息。料号查询可扫描二维码，输入6位数字的主料号即可搜索。





ARaymond   
MORE THAN FASTENING

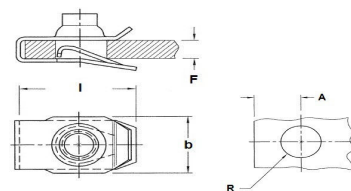

ARaymond   
MORE THAN FASTENING  

| Part Number     | Thread Specification | Panel Thickness (F) | Throat Distance (A) | Hole Diameter (R) | Width (b) | Length (I) |
|-----------------|----------------------|---------------------|---------------------|-------------------|-----------|------------|
| <b>Imperial</b> |                      |                     |                     |                   |           |            |
| 138337          | 8-32                 | 0.020 - 0.079       | 0.383               | 0.280 - 0.280     | 0.492     | 0.681      |
| 138347          | 10-32                | 0.070 - 0.100       | 0.27                | 0.260 - 0.260     | 0.51      | 0.6        |
| 138332          | 2001-4-20            | 0.025 - 0.150       | 0.45                | 0.390 - 0.390     | 0.56      | 0.92       |
| 138334          | 5/16-18              | 0.025 - 0.150       | 0.5                 | 0.437 - 0.437     | 0.67      | 0.98       |
| 138333          | 2003-8-16            | 0.050 - 0.200       | 0.66                | 0.562 - 0.562     | 0.93      | 1.29       |
| <b>Metric</b>   |                      |                     |                     |                   |           |            |
| 135211          | ST4.2 (8-18)         | 2.00 - 3.00         | 8.6                 | 7.93 - 7.93       | 12.5      | 16.9       |
| 138056          | ST4.2 (8-18)         | 0.50 - 2.00         | 9.1                 | 7.93 - 7.93       | 12.5      | 17.3       |
| 138280          | ST4.2 (8-18)         | 0.65 - 3.80         | 14                  | 7.55 - 7.55       | 12.5      | 22         |

Remarks: ARaymond-Tinnerman's Part number is generally composed of 9 digits. The main number is composed of the first 6 digits, and the last 3 digits indicate the surface treatment and color requirement. For further information, please scan the QR code or conduct a direct search of the first 6 digits.

备注：Tinnerman的物料号一般是由9位数字组成，前6位数字为主料号，最后3位数字表示物料的表面处理等信息。料号查询可扫描二维码，输入6位数字的主料号即可搜索。



tinnerman.dbfasteners.cn







## Railway & Subway 铁路和地铁

We provide dozens of railway customers with Huck.

我们向众多的铁路客户提供HUCK产品。

### Lock Bolts 环槽铆钉

BOBTAIL



C50L



C6L



MAGNA-GRIP



MAGNA-LOK



### Blind Rivets by Huck 盲拉铆钉

BOM



MAGNA-BULB



AUTO-BULB



### Tooling and Maintenance 工具及维护



Unlike conventional nuts and bolts, HuckBolts® and structural blind rivets are the result of advanced engineering and manufacturing processes.

## Not Just Manufactured. Huck® Engineered

## 不仅仅是制造 Huck®工程

与传统的螺母和螺栓不同，HuckBolts®和结构盲铆钉是先进工程和制造过程的结果。



[huck.dbfasteners.cn](http://huck.dbfasteners.cn)



ARCONIC

HUCK

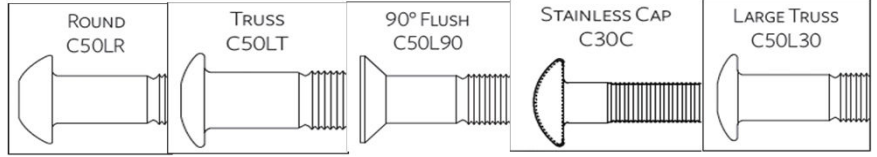
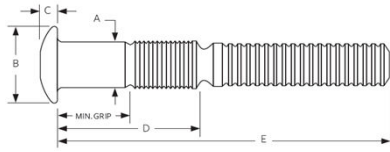

**Fastener Dimensions**

| Part No.       | Diameter | Grip Range    | Max Hole Size | A             | [B] Head Dia (max) | [C] Head Height (max) | D     | E     | Typical Shear (lbs) | Typical Clamp (lbf) | Typical Tensile (lbs) |
|----------------|----------|---------------|---------------|---------------|--------------------|-----------------------|-------|-------|---------------------|---------------------|-----------------------|
| C50LR          |          |               |               |               |                    |                       |       |       |                     |                     |                       |
| C50LR-BR20-4   | 5/8"     | .250 - .500   | 0.688         | 0.642 - 0.617 | 1.141              | 0.397                 | 1.433 | 3.656 | 22500               | 19200               | 27100                 |
| C50LR-BR20-8   | 5/8"     | .500 - .750   | 0.688         | 0.642 - 0.617 | 1.141              | 0.397                 | 1.683 | 3.906 | 22500               | 19200               | 27100                 |
| C50LR-BR20-12  | 5/8"     | .750 - 1.000  | 0.688         | 0.642 - 0.617 | 1.141              | 0.397                 | 1.933 | 4.156 | 22500               | 19200               | 27100                 |
| C50LR-BR20-16  | 5/8"     | 1.000 - 1.250 | 0.688         | 0.642 - 0.617 | 1.141              | 0.397                 | 2.183 | 4.406 | 22500               | 19200               | 27100                 |
| C50LR-BR20-20  | 5/8"     | 1.250 - 1.500 | 0.688         | 0.642 - 0.617 | 1.141              | 0.397                 | 2.433 | 4.656 | 22500               | 19200               | 27100                 |
| C50LR-BR20-24  | 5/8"     | 1.500 - 1.750 | 0.688         | 0.642 - 0.617 | 1.141              | 0.397                 | 2.683 | 4.906 | 22500               | 19200               | 27100                 |
| C50LR-BR20-28  | 5/8"     | 1.750 - 2.000 | 0.688         | 0.642 - 0.617 | 1.141              | 0.397                 | 2.933 | 5.156 | 22500               | 19200               | 27100                 |
| C50LR-BR20-32  | 5/8"     | 2.000 - 2.250 | 0.688         | 0.642 - 0.617 | 1.141              | 0.397                 | 3.183 | 5.406 | 22500               | 19200               | 27100                 |
| C50LR-BR24-8   | 3/4"     | .500 - .750   | 0.813         | 0.768 - 0.741 | 1.383              | 0.495                 | 1.768 | 4.406 | 32400               | 28400               | 40100                 |
| C50LR-BR24-12  | 3/4"     | .750 - 1.000  | 0.813         | 0.768 - 0.741 | 1.383              | 0.495                 | 2.018 | 4.656 | 32400               | 28400               | 40100                 |
| C50LR-BR24-16  | 3/4"     | 1.000 - 1.250 | 0.813         | 0.768 - 0.741 | 1.383              | 0.495                 | 2.268 | 4.906 | 32400               | 28400               | 40100                 |
| C50LR-BR24-20  | 3/4"     | 1.250 - 1.500 | 0.813         | 0.768 - 0.741 | 1.383              | 0.495                 | 2.518 | 5.156 | 32400               | 28400               | 40100                 |
| C50LR-BR24-24  | 3/4"     | 1.500 - 1.750 | 0.813         | 0.768 - 0.741 | 1.383              | 0.495                 | 2.768 | 5.406 | 32400               | 28400               | 40100                 |
| C50LR-BR24-28  | 3/4"     | 1.750 - 2.000 | 0.813         | 0.768 - 0.741 | 1.383              | 0.495                 | 3.018 | 5.656 | 32400               | 28400               | 40100                 |
| C50LR-BR24-32  | 3/4"     | 2.000 - 2.250 | 0.813         | 0.768 - 0.741 | 1.383              | 0.495                 | 3.268 | 5.906 | 32400               | 28400               | 40100                 |
| C50LR-BR32-16  | 1"       | 1.000 - 1.250 | 1.063         | 1.025 - 0.990 | 1.85               | 0.618                 | 2.573 | 5.875 | 56500               | 51500               | 72700                 |
| C50LR-BR32-20  | 1"       | 1.250 - 1.500 | 1.063         | 1.025 - 0.990 | 1.85               | 0.618                 | 2.823 | 6.125 | 56500               | 51500               | 72700                 |
| C50LR-BR32-24  | 1"       | 1.500 - 1.750 | 1.063         | 1.025 - 0.990 | 1.85               | 0.618                 | 3.073 | 6.375 | 56500               | 51500               | 72700                 |
| C50LR-BR32-28  | 1"       | 1.750 - 2.000 | 1.063         | 1.025 - 0.990 | 1.85               | 0.618                 | 3.323 | 6.625 | 56500               | 51500               | 72700                 |
| C50LR-BR32-32  | 1"       | 2.000 - 2.250 | 1.063         | 1.025 - 0.990 | 1.85               | 0.618                 | 3.573 | 6.875 | 56500               | 51500               | 72700                 |
| C50LR-BR32-36  | 1"       | 2.250 - 2.500 | 1.063         | 1.025 - 0.990 | 1.85               | 0.618                 | 3.823 | 7.125 | 56500               | 51500               | 72700                 |
| C50LR-BR32-40  | 1"       | 2.500 - 2.750 | 1.063         | 1.025 - 0.990 | 1.85               | 0.618                 | 4.073 | 7.375 | 56500               | 51500               | 72700                 |
| C50L90-BR20-8  | 5/8"     | .500 - .750   | 0.688         | 0.642 - 0.617 | 1.14               | 0.313                 | 1.683 | 3.906 | 22500               | 19200               | 27100                 |
| C50L90-BR20-12 | 5/8"     | .750 - 1.000  | 0.688         | 0.642 - 0.617 | 1.14               | 0.313                 | 1.933 | 4.156 | 22500               | 19200               | 27100                 |
| C50L90-BR20-16 | 5/8"     | 1.000 - 1.250 | 0.688         | 0.642 - 0.617 | 1.14               | 0.313                 | 2.183 | 4.406 | 22500               | 19200               | 27100                 |

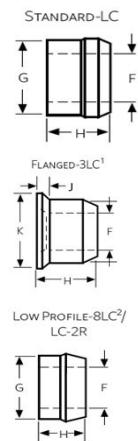

**Collar Dimensions**

| Part No.  | Diameter | F             | G             | H                          | J             | K             |
|-----------|----------|---------------|---------------|----------------------------|---------------|---------------|
| LC-2R16G  | 1/2"     | 0.515 - 0.535 | 0.800 - 0.765 | 0.645 - 0.610              |               |               |
| LC-2R20G  | 5/8"     | 0.650 - 0.665 | 0.985 - 0.970 | 0.875 - 0.845 <sup>3</sup> |               |               |
| LC-2R24G  | 3/4"     | 0.775 - 0.790 | 1.180 - 1.165 | 0.960 - 0.930              |               |               |
| LC-2R28G  | 7/8"     | 0.915 - 0.920 | 1.375 - 1.360 | 1.113 - 1.083              | —             | —             |
| LC-2R32G  | 1"       | 1.035 - 1.050 | 1.570 - 1.550 | 1.275 - 1.240              | —             | —             |
| LC-2R36G  | 1-1/8"   | 1.165 - 1.185 | 1.770 - 1.750 | 1.440 - 1.390              | —             | —             |
| 3LC-2R16G | 1/2"     | 0.510 - 0.530 | 0.807 - 0.793 | 0.760 - 0.722              | 0.130 - 0.120 | 1.035 - 0.980 |
| 3LC-2R20G | 5/8"     | 0.648 - 0.660 | 0.996 - 0.980 | 0.962 - 0.926              | 0.170 - 0.142 | 1.273 - 1.227 |
| 3LC-2R24G | 3/4"     | 0.775 - 0.793 | 1.195 - 1.175 | 1.150 - 1.115              | 0.200 - 0.175 | 1.520 - 1.480 |
| 3LC-2R28G | 7/8"     | 0.895 - 0.907 | 1.370 - 1.360 | 1.333 - 1.300              | 0.230 - 0.205 | 1.615 - 1.575 |
| 3LC-2R32G | 1"       | 1.035 - 1.050 | 1.565 - 1.550 | 1.520 - 1.480              | 0.263 - 0.237 | 1.893 - 1.854 |

Remarks: Take C50L as an example, the composition of the item number is as follows.  
 C50L (SERIES) R(HEAD STYLE) - (MATERIAL) (DIAMETER) - (GRIP NUMBER)  
 Example: C50LR-BR20-4 is a C50L HUCKBOLT fastener, Round Head, Carbon Steel, 5/8" Diameter, Grip (0.250~0.500)

For more details, please scan the QR code, or conduct a direct search of the number.

备注：以C50LR-BR20-4型号为例，料号的组成如下：  
 C50L为HUCK铆钉产品系列，R为头型代码（圆头），BR为材料代码（碳钢），20为直径代码（5/8"），4为夹紧范围代码（0.250~0.500）。  
 详细料号信息可扫描二维码，或者直接搜索主料号。



huck.dbfasteners.cn



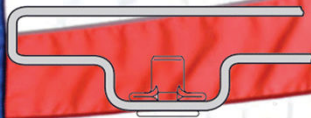

## Electronic Equipment

## 电气设备

The industrial market covers various segments, such as:

我们的产品范围适用于各种不同的行业，例如：

White goods 白色家电

HVAC 采暖通风与空调

Railway & Subway 铁路&地铁

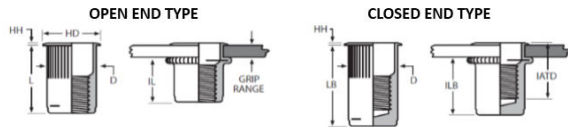

| Part No.       | THREAD SIZE  | THREAD CALL OUT | GRIP RANGE  | GRIP CALL OUT | HOLE SIZE<br>+0,15 / -0,00 | HD<br>±0,38 | HH<br>±0,08 | L<br>±0,38 | D MAX. | IL MAX. | LB MAX. | ILB MAX. | IATD** MAX. |
|----------------|--------------|-----------------|-------------|---------------|----------------------------|-------------|-------------|------------|--------|---------|---------|----------|-------------|
| AKS1-470-2.0   | M4 x 0,7 ISO | 470             | 0,50 - 2,00 | 2,0           | 6,75                       | 7,87        | 0,48        | 10,67      | 6,73   | 7,75    | —       | —        | —           |
| AKS2-470-2.0   | M4 x 0,7 ISO | 470             | 0,50 - 2,00 | 2,0           | 6,75                       | 7,87        | 0,48        | 10,67      | 6,73   | 7,75    | —       | —        | —           |
| AKS3-470-2.0   | M4 x 0,7 ISO | 470             | 0,50 - 2,00 | 2,0           | 6,75                       | 7,87        | 0,48        | 10,67      | 6,73   | 7,75    | —       | —        | —           |
| AKS3R-470-2.0  | M4 x 0,7 ISO | 470             | 0,50 - 2,00 | 2,0           | 6,75                       | 7,87        | 0,48        | 10,67      | 6,73   | 7,75    | —       | —        | —           |
| AKS3T-470-2.0  | M4 x 0,7 ISO | 470             | 0,50 - 2,00 | 2,0           | 6,75                       | 7,87        | 0,48        | 10,67      | 6,73   | 7,75    | —       | —        | —           |
| AKS4-470-2.0   | M4 x 0,7 ISO | 470             | 0,50 - 2,00 | 2,0           | 6,75                       | 7,87        | 0,48        | 10,67      | 6,73   | 7,75    | —       | —        | —           |
| AKS4T-470-2.0  | M4 x 0,7 ISO | 470             | 0,50 - 2,00 | 2,0           | 6,75                       | 7,87        | 0,48        | 10,67      | 6,73   | 7,75    | —       | —        | —           |
| AKS5-470-2.0   | M4 x 0,7 ISO | 470             | 0,50 - 2,00 | 2,0           | 6,75                       | 7,87        | 0,48        | 10,67      | 6,73   | 7,75    | —       | —        | —           |
| AKS6-470-2.0   | M4 x 0,7 ISO | 470             | 0,50 - 2,00 | 2,0           | 6,75                       | 7,87        | 0,48        | 10,67      | 6,73   | 7,75    | —       | —        | —           |
| AKS7-470-2.0   | M4 x 0,7 ISO | 470             | 0,50 - 2,00 | 2,0           | 6,75                       | 7,87        | 0,48        | 10,67      | 6,73   | 7,75    | —       | —        | —           |
| AKS1-470-2.0B  | M4 x 0,7 ISO | 470             | 0,50 - 2,00 | 2,0           | 6,75                       | 7,87        | 0,48        | —          | 6,73   | —       | 19,18   | 16,26    | 15,49       |
| AKS2-470-2.0B  | M4 x 0,7 ISO | 470             | 0,50 - 2,00 | 2,0           | 6,75                       | 7,87        | 0,48        | —          | 6,73   | —       | 19,18   | 16,26    | 15,49       |
| AKS3-470-2.0B  | M4 x 0,7 ISO | 470             | 0,50 - 2,00 | 2,0           | 6,75                       | 7,87        | 0,48        | —          | 6,73   | —       | 19,18   | 16,26    | 15,49       |
| AKS3R-470-2.0B | M4 x 0,7 ISO | 470             | 0,50 - 2,00 | 2,0           | 6,75                       | 7,87        | 0,48        | —          | 6,73   | —       | 19,18   | 16,26    | 15,49       |
| AKS3T-470-2.0B | M4 x 0,7 ISO | 470             | 0,50 - 2,00 | 2,0           | 6,75                       | 7,87        | 0,48        | —          | 6,73   | —       | 19,18   | 16,26    | 15,49       |
| AKS4-470-2.0B  | M4 x 0,7 ISO | 470             | 0,50 - 2,00 | 2,0           | 6,75                       | 7,87        | 0,48        | —          | 6,73   | —       | 19,18   | 16,26    | 15,49       |
| AKS4T-470-2.0B | M4 x 0,7 ISO | 470             | 0,50 - 2,00 | 2,0           | 6,75                       | 7,87        | 0,48        | —          | 6,73   | —       | 19,18   | 16,26    | 15,49       |
| AKS5-470-2.0B  | M4 x 0,7 ISO | 470             | 0,50 - 2,00 | 2,0           | 6,75                       | 7,87        | 0,48        | —          | 6,73   | —       | 19,18   | 16,26    | 15,49       |
| AKS6-470-2.0B  | M4 x 0,7 ISO | 470             | 0,50 - 2,00 | 2,0           | 6,75                       | 7,87        | 0,48        | —          | 6,73   | —       | 19,18   | 16,26    | 15,49       |
| AKS7-470-2.0B  | M4 x 0,7 ISO | 470             | 0,50 - 2,00 | 2,0           | 6,75                       | 7,87        | 0,48        | —          | 6,73   | —       | 19,18   | 16,26    | 15,49       |

Remarks: The composition of the AVK part number is as follows. For more details, please scan the QR code or directly search for the part number.

备注：AVK料号的组成结构如下，详细料号查询请扫描二维码，或者进行料号的直接搜索。



avk.dbfasteners.cn

SAMPLE NUMBER:AKS4T-470-2.0

|                       |                 |                 |   |   |                        |
|-----------------------|-----------------|-----------------|---|---|------------------------|
| <b>AK</b>             | <b>( )</b>      | <b>( )</b>      | <b>-( )</b>                                       | <b>-( )</b>   | <b>( )</b>             |
| <b>PRODUCT SERIES</b> | <b>MATERIAL</b> |                 | <b>FINISH ROHS COMPLIANT</b>                      |   | <b>THREAD CALL OUT</b> |
|                       | <b>CALL OUT</b> | <b>GRADE</b>    | <b>CALL OUT</b>                                   | <b>SPECIFICATION</b>  | <b>GRIP CALL OUT</b>   |
|                       | S               | Steel 1010/1008 | 3T  | ZINC TRIVALENT PERASTIM-B-633, FE/ZN.0003 (8µ) WITH CLEAR PROTECTIVE COATING        |                        |
|                       | A               | Aluminum 5056   | 4T  | YELLOW ZINC TRIVALENT PERASTIM-B-633, FE/ZN.0003 (8µ) WITH CLEAR PROTECTIVE COATING |                        |
|                       | B               | Brass 270/260   | 9T  | TIN ZINC TRIVALENT PERESP-P-004.0003 (8µ) WITH CLEAR PROTECTIVE COATING             |                        |
|                       | M               | Monel 400       | Note: For Additional Plating See Chart on Page 47 |   |                        |
|                       |                 |                 |   |   | <b>TYPE</b>            |
|                       |                 |                 |   |   | <b>CALL OUT</b>        |
|                       |                 |                 |   |   | <b>TYPE</b>            |
|                       |                 |                 |   |   | BLANK                  |
|                       |                 |                 |   |   | Open End               |
|                       |                 |                 |   |   | B                      |
|                       |                 |                 |   |   | Closed End             |



# General Industry

## 一般工业

World class fasteners for world class manufacturers

我们为世界级的制造商提供世界级的紧固件

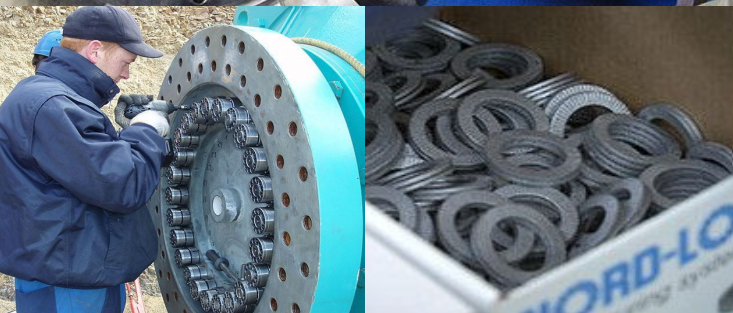

Drag Slats and Elevators

矿井电梯

Vibrating Screens

振动筛

Power Generation

发电

Construction & Infrastructure

建筑与基础设施



[nordlock.dbfasteners.cn](http://nordlock.dbfasteners.cn)









## Standard Fasteners

### 标准紧固件



#### SCREWS AND BOLTS

螺丝和螺栓

ASME SERIES

DIN931,DIN933,DIN912,DIN7981,DIN7982

GB70,GB818,GB819,GB845,GB846

ISO4017,ISO4026

...

#### NUT

螺母

ASME SERIES

DIN934,DIN985,

GB6177

ISO4032

...

#### WASHER

垫圈

DIN125,DIN127,DIN128

.....

#### RETAINING RING

止动环

DIN471 DSH SHAFT RINGS

DIN472 DHO HOUSING RINGS

.....

#### MATERIAL

材料

CARBON STEEL, STAINLESS STEEL...

#### FINISH

表面处理

PHOSPHATE, ZINC DICHROMATE...





# Authorized Distributor Certificate

This is to certify that  
**DB Fasteners (China) Limited**

is an authorized non-exclusive distributor for  
Rotor Clip Company, Inc.  
retaining rings and related products

Valid for 3 years effective from November 1, 2017



Craig Slass, Owner  
Rotor Clip Company, Inc.

Rotor Clip Company, Inc. 187 Davidson Avenue, Somerset, NJ 08873 USA



ARaymond <sup>9E</sup>  
MORE THAN FASTENING

## 区域代理授权证书

阿雷蒙汽车紧固件（镇江）有限公司

谨此授权

DB Fasteners (China) Limited  
上海邓肯勃贸易有限公司

为塑料和金属紧固件产品在\_上海\_的授权经销商

Sun Zhiguan  
Managing Director  
总经理

# Authorized 授权



## OFFICIAL DISTRIBUTOR AUTHORIZATION CERTIFICATE

This serves to confirm the appointment of

DB Fasteners (China) Limited  
Room 301, Building #3, No.51 Lane  
1895 Hutai Road, Jing'An District,  
Shanghai, China

*As a non-exclusive Distributor for Arconic Fastening Systems Co., Ltd. (Including Arconic Fastening Systems Suzhou Co., Ltd.) and Huck International, Inc., for AFS Fasteners, assembly equipment and repair parts for general industry, including the passenger rail car, throughout the People's Republic of China*

Effective date: Dec. 2018

Expire date: Dec.2019

Signed for, and on behalf of the below:

Jim Arnold  
Vice President & General Manager  
Global Operations  
For Arconic Fastening Systems  
and  
Huck International, Inc  
Date: 12/31/2018



AVK INDUSTRIAL PRODUCTS  
A PCC COMPANY

Recognizes

DB Fasteners (China) Ltd



As Our First  
Authorized Distributor  
In China

March, 2007





**DB** FASTENERS  
Helping make the right connections

DB Fasteners (China) Ltd  
上海邓肯勃贸易有限公司

Telephone

电话:

+86 (21) 5186-3340

Fax

传真:

+86 (21) 3360-0150

Website

网址:

[www.dbfasteners.cn](http://www.dbfasteners.cn)

Address

地址:

Room #301, Building #3, Lane  
#51,  
1895 Hutai Road, Jing'an District,  
Shanghai, China.  
上海市静安区沪太路 1895 弄 51  
号 3 号楼 301 室  
200436

Public Account on WeChat

公众号

